

**STANDARD DETAILS  
MANHOLE**

**BLAIR TOWNSHIP WATER AND SEWER AUTHORITY  
RULES, REGULATIONS AND POLICY**

377 CEDARCREST DRIVE DUNCANSVILLE, PA 16635  
OFFICE: (814) 695-6300 FAX: (814) 696-5757  
TTY/TDD ONLY: 1-800-654-5984

BLAIR TOWNSHIP, BLAIR COUNTY  
PENNSYLVANIA

KELLER ENGINEERS, INC.  
420 ALLEGHENY STREET  
HOLLIDAYSBURG, PA 16648  
PHONE: 814-696-7430  
FAX: 814-696-0150

**KELLER ENGINEERS**

In accordance with Federal law and U.S. Department of Agriculture policy, this institution is prohibited from discriminating on the basis of race, color, national origin, sex, age, or disability. (Not all prohibited bases apply to all programs). To file a complaint of discrimination, write USDA, Director, Office of Civil Rights, 1400 Independence Avenue, S.W., Washington D.C. 20250-9410, or call (800) 795-3272 (voice), or (202) 720-6382 (TDD)

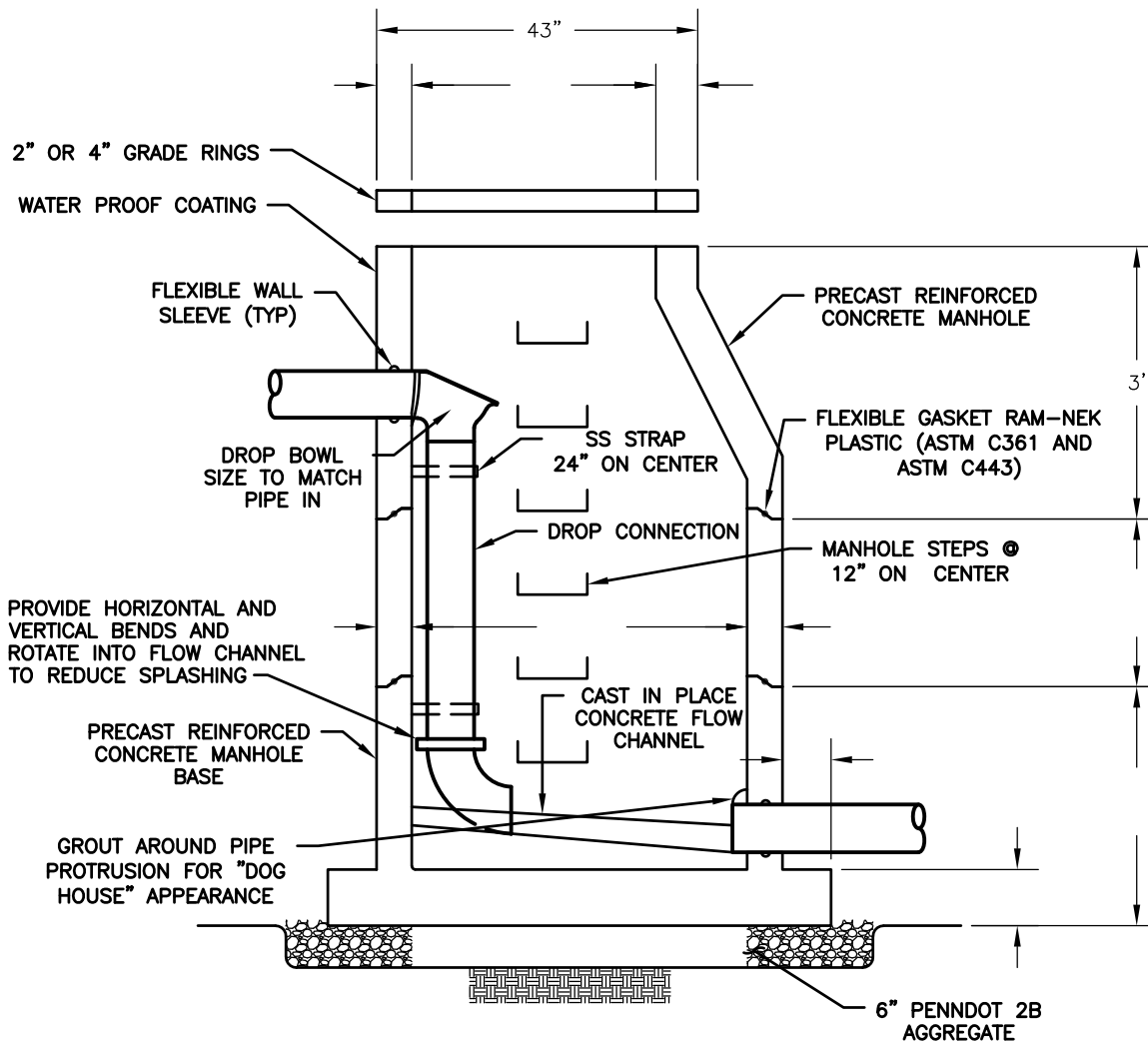

## STANDARD DETAILS DROP MANHOLE

### BLAIR TOWNSHIP WATER AND SEWER AUTHORITY RULES, REGULATIONS AND POLICY

377 CEDARCREST DRIVE DUNCANVILLE, PA 16635

OFFICE: (814) 695-6300 FAX: (814) 696-5757

TTY/TDD ONLY: 1-800-654-5984

BLAIR TOWNSHIP, BLAIR COUNTY  
PENNSYLVANIA

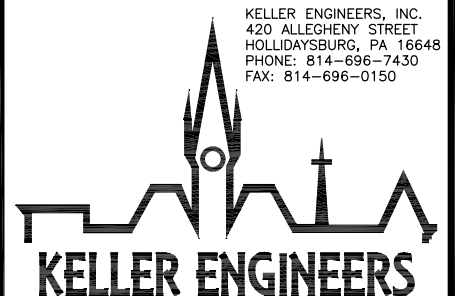

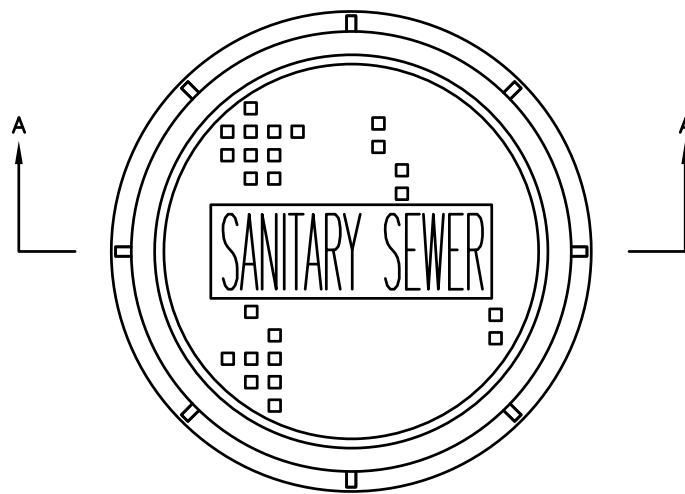
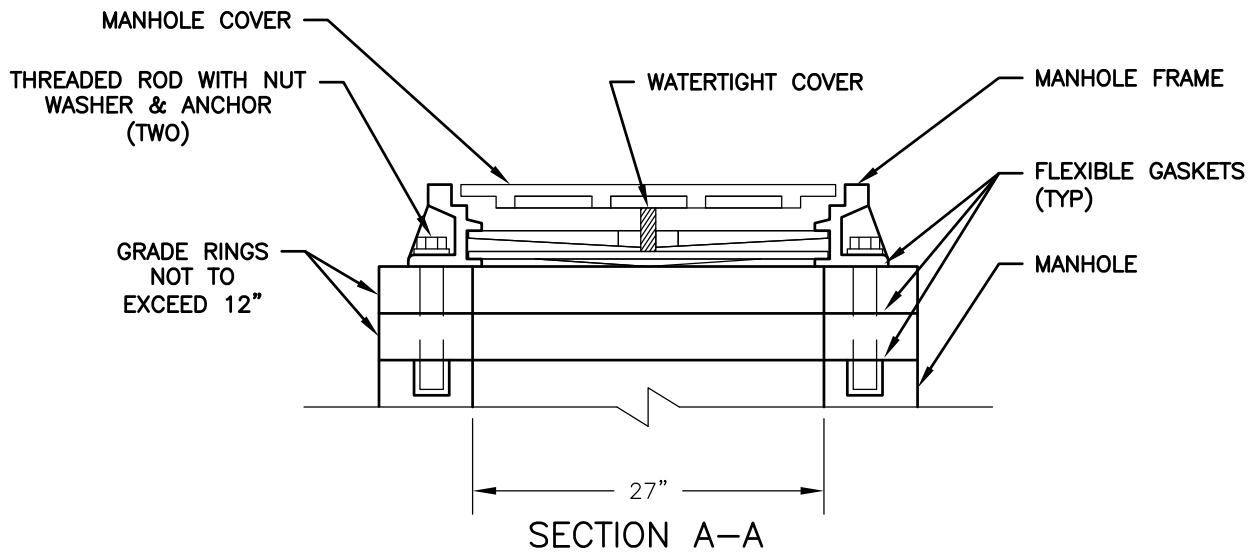

## STANDARD DETAILS MANHOLE FRAME AND COVER

### BLAIR TOWNSHIP WATER AND SEWER AUTHORITY RULES, REGULATIONS AND POLICY

377 CEDARCREST DRIVE DUNCANSVILLE, PA 16635  
OFFICE: (814) 695-6300 FAX: (814) 696-5757  
TTY/TDD ONLY: 1-800-654-5984

BLAIR TOWNSHIP, BLAIR COUNTY  
PENNSYLVANIA

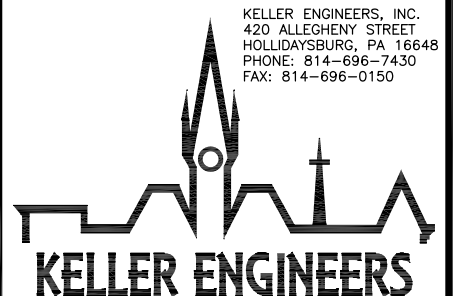

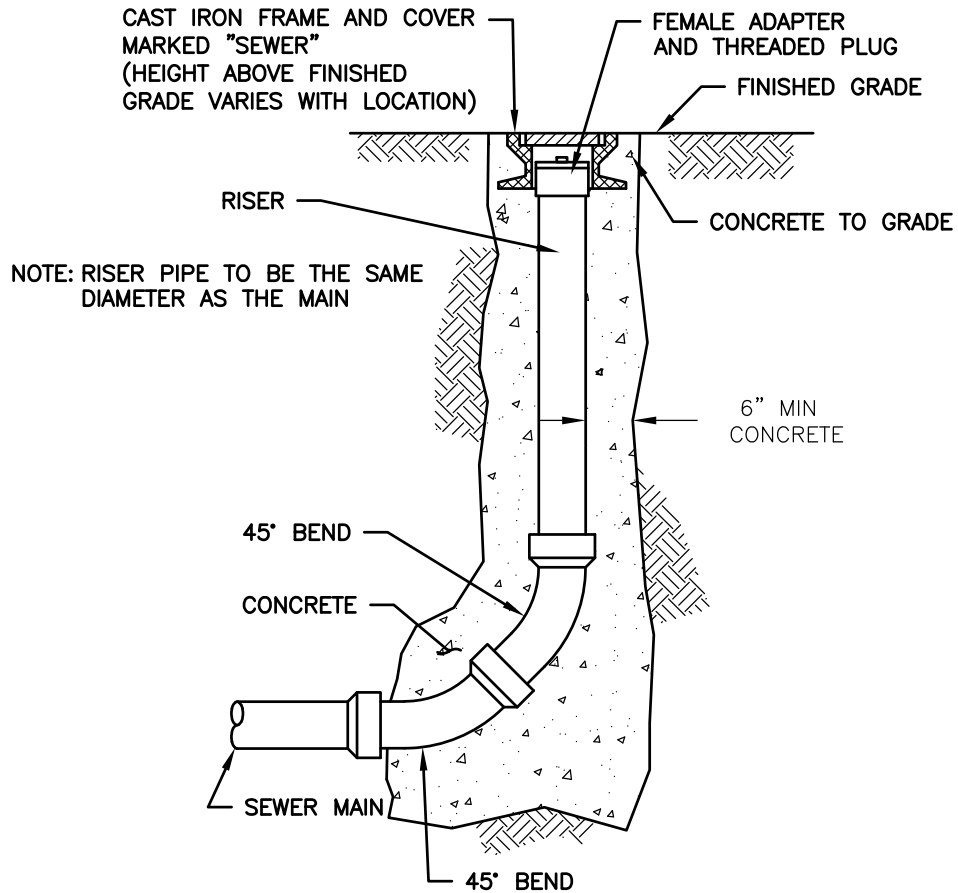

**STANDARD DETAILS  
CLEANOUT**

**BLAIR TOWNSHIP WATER AND SEWER AUTHORITY  
RULES, REGULATIONS AND POLICY**

377 CEDARCREST DRIVE DUNCANSVILLE, PA 16635  
 OFFICE: (814) 695-6300 FAX: (814) 696-5757  
 TTY/TDD ONLY: 1-800-654-5984

BLAIR TOWNSHIP, BLAIR COUNTY  
 PENNSYLVANIA

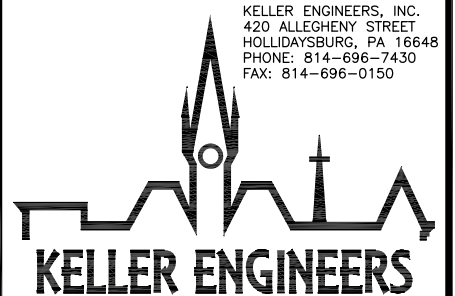

CAST IRON FRAME AND COVER  
 MARKED "SEWER" (HEIGHT ABOVE  
 FINISHED GRADE VARIES WITH  
 LOCATION; PROVIDE SILICON SEAL)

FINISHED GRADE

FLEXIBLE INSULATION  
 PAD

2" THREADED BRASS  
 NIPPLE AND CAP

2" BALL VALVE

6" MIN  
 CONCRETE

12"

1/2" DRAINAGE HOLES  
 IN STONE BACKFILL  
 SECTION OF PIPE

MIN 18" PVC  
 (SDR 35)

2B STONE FILL

45° BEND

CONCRETE FILL  
 MUST COVER ALL  
 JOINTED PIPES

WYE

END OF MAIN CLEANOUT TO  
 HAVE 2' STUB WITH CAP

18" PVC (SDR 35) OR METER BOX  
 OPTION 1: PLACE ON TOP OF CONCRETE  
 OPTION 2: USE PIPE/BOX AS HOUSING FOR  
 CONCRETE AND DRILL HOLES AROUND THE  
 PIPE/BOX WHERE IT MEETS CONCRETE

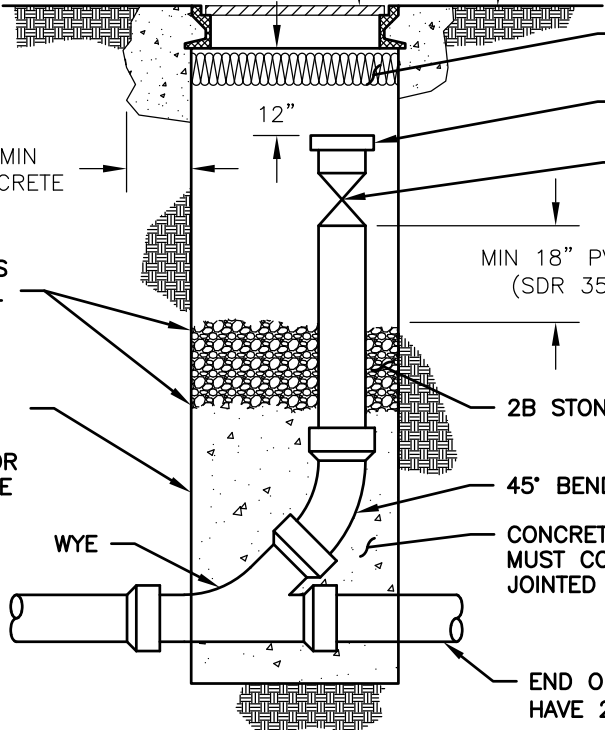

**STANDARD DETAILS  
 PRESSURE CLEANOUT**

**BLAIR TOWNSHIP WATER AND SEWER AUTHORITY  
 RULES, REGULATIONS AND POLICY**

377 CEDARCREST DRIVE DUNCANVILLE, PA 16635  
 OFFICE: (814) 695-6300 FAX: (814) 696-5757  
 TTY/TDD ONLY: 1-800-654-5984

BLAIR TOWNSHIP, BLAIR COUNTY  
 PENNSYLVANIA

KELLER ENGINEERS, INC.  
 420 ALLEGHENY STREET  
 HOLLIDAYSBURG, PA 16648  
 PHONE: 814-696-7430  
 FAX: 814-696-0150

**KELLER ENGINEERS**

In accordance with Federal law and U.S. Department of Agriculture policy, this institution is prohibited from discriminating on the basis of race, color, national origin, sex, age, or disability. (Not all prohibited bases apply to all programs). To file a complaint of discrimination, write USDA, Director, Office of Civil Rights, 1400 Independence Avenue, S.W., Washington D.C. 20250-9410, or call (800) 795-3272 (voice), or (202) 720-6382 (TDD)

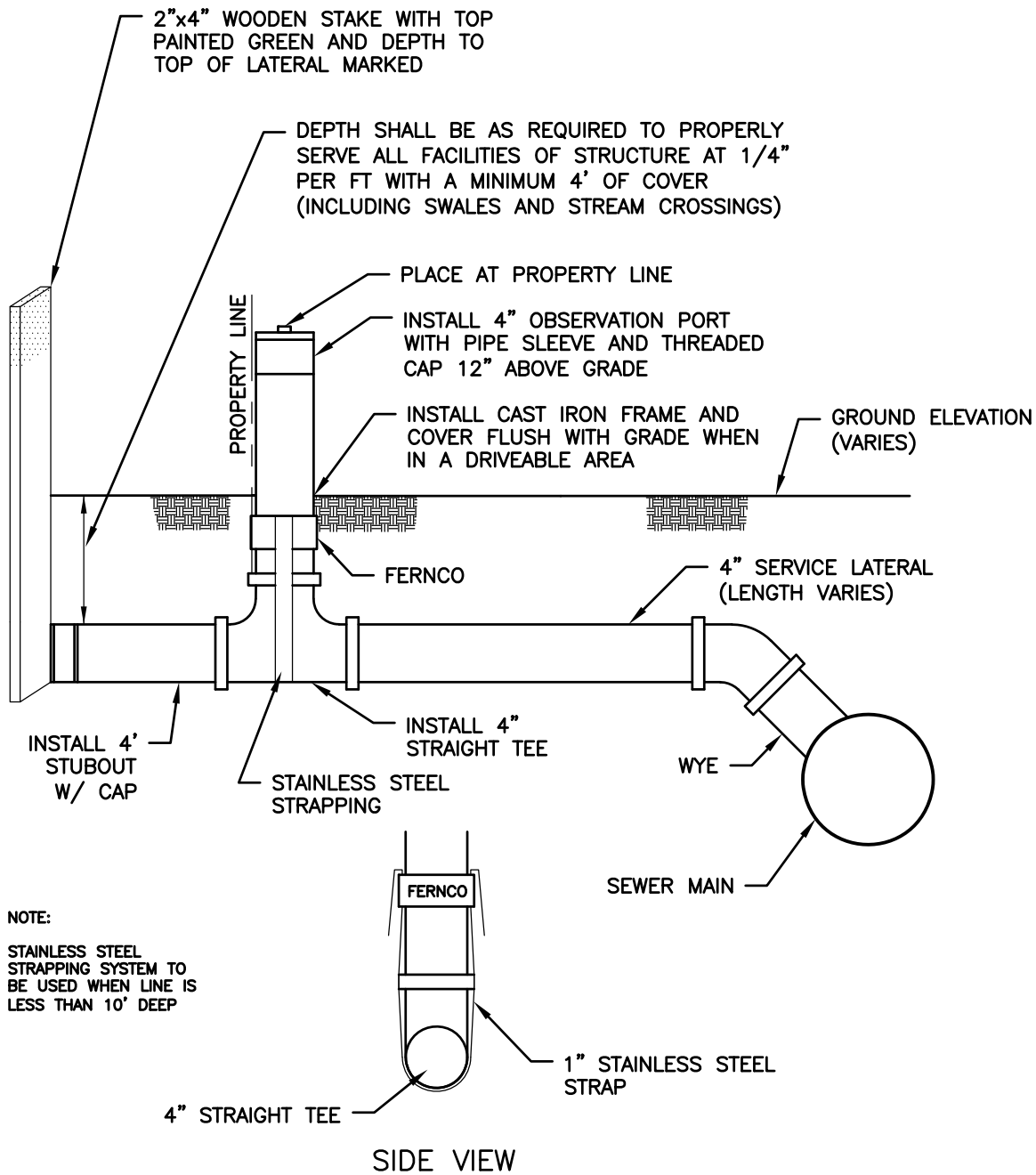

## STANDARD DETAILS SEWER SERVICE LATERAL

BLAIR TOWNSHIP WATER AND SEWER AUTHORITY  
RULES, REGULATIONS AND POLICY

377 CEDARCREST DRIVE DUNCANVILLE, PA 16635  
OFFICE: (814) 695-6300 FAX: (814) 696-5757  
TTY/TDD ONLY: 1-800-654-5984  
BLAIR TOWNSHIP, BLAIR COUNTY  
PENNSYLVANIA

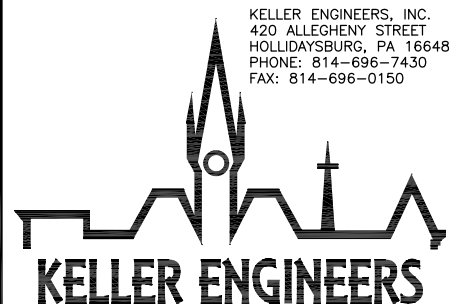

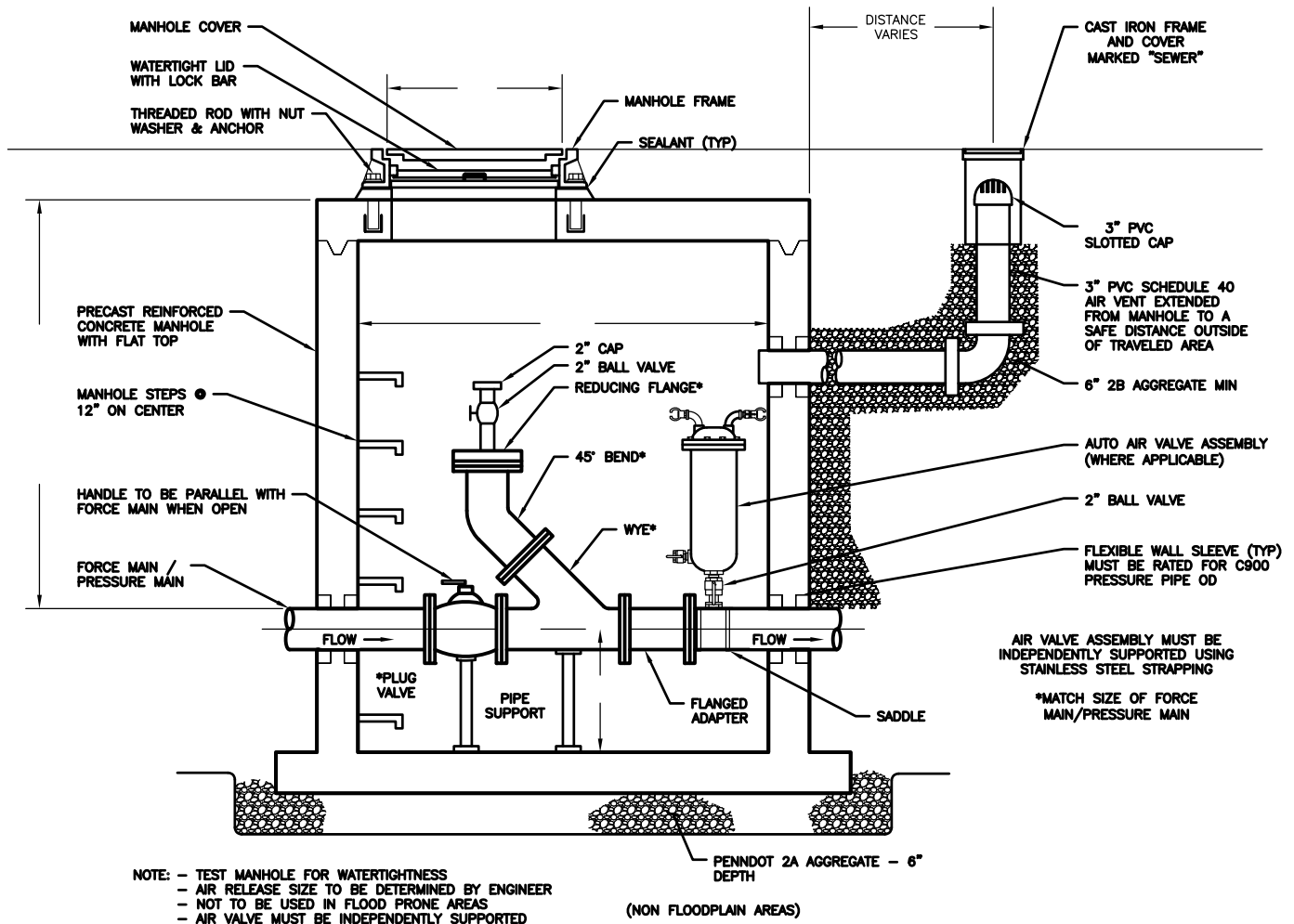

**STANDARD DETAILS**  
**FORCE MAIN CLEANOUT/  
 AIR VALVE ASSEMBLY**

BLAIR TOWNSHIP WATER AND SEWER AUTHORITY  
 RULES, REGULATIONS AND POLICY  
 377 CEDARCREST DRIVE DUNCANVILLE, PA 16635  
 OFFICE: (814) 695-6300 FAX: (814) 696-5757  
 TTY/TDD ONLY: 1-800-654-5984  
 BLAIR TOWNSHIP, BLAIR COUNTY  
 PENNSYLVANIA

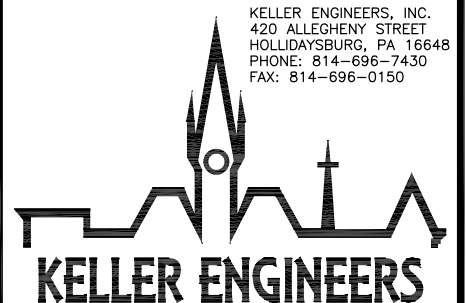

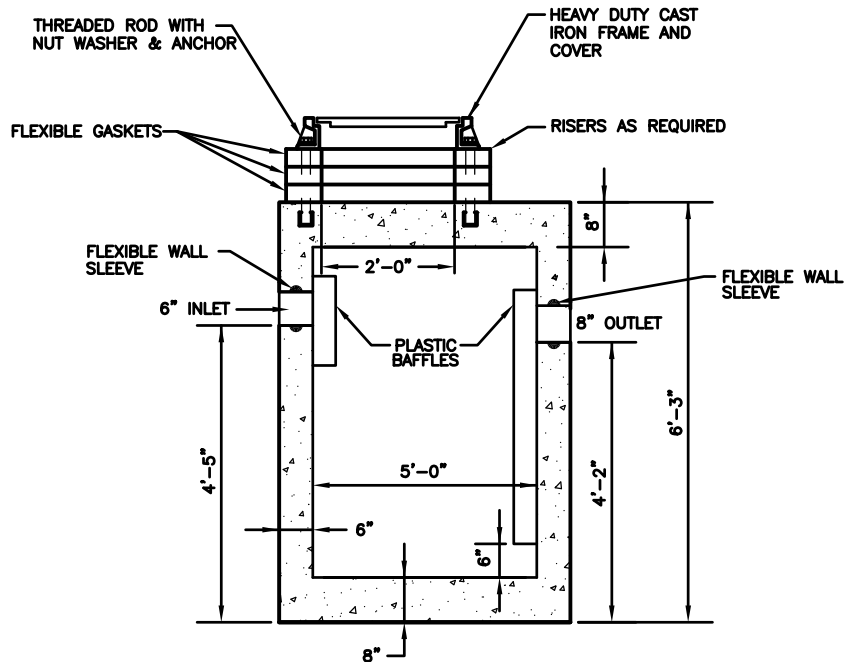

**NOTE:**  
CAPACITY - 500 GALLON, MONARCH  
PRODUCTS COMPANY, INC OR EQUAL

## STANDARD DETAILS GREASE AND OIL INTERCEPTOR

BLAIR TOWNSHIP WATER AND SEWER AUTHORITY  
RULES, REGULATIONS AND POLICY

377 CEDARCREST DRIVE DUNCANSVILLE, PA 16635  
OFFICE: (814) 695-6300 FAX: (814) 696-5757  
TTY/TDD ONLY: 1-800-654-5984

BLAIR TOWNSHIP, BLAIR COUNTY  
PENNSYLVANIA

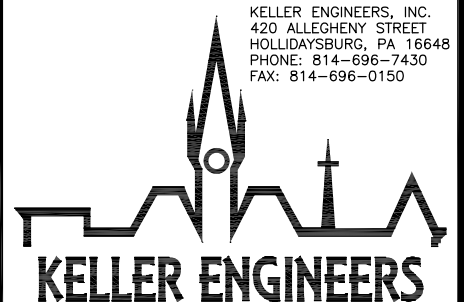

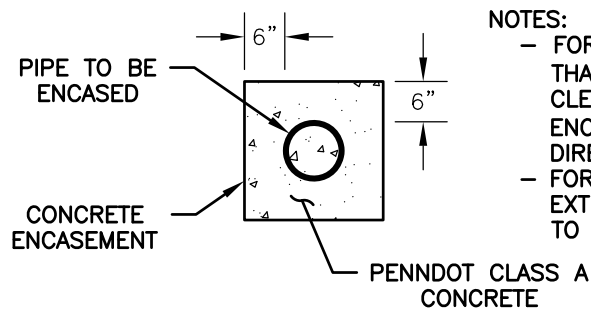

**NOTES:**

- FOR UTILITY CROSSING WITH LESS THAN 18" OF VERTICAL CLEARING: EXTEND CONCRETE ENCASEMENT 4.5' IN BOTH DIRECTIONS FROM CROSSING
- FOR MINOR STREAM CROSSINGS: EXTEND CONCRETE ENCASEMENT TO BOTH STREAM BANKS

**STANDARD DETAILS  
CONCRETE ENCASEMENT**

**BLAIR TOWNSHIP WATER AND SEWER AUTHORITY  
RULES, REGULATIONS AND POLICY**

377 CEDARCREST DRIVE DUNCANSVILLE, PA 16635  
OFFICE: (814) 695-6300 FAX: (814) 696-5757  
TTY/TDD ONLY: 1-800-654-5984

BLAIR TOWNSHIP, BLAIR COUNTY  
PENNSYLVANIA

KELLER ENGINEERS, INC.  
420 ALLEGHENY STREET  
HOLLIDAYSBURG, PA 16648  
PHONE: 814-696-7430  
FAX: 814-696-0150

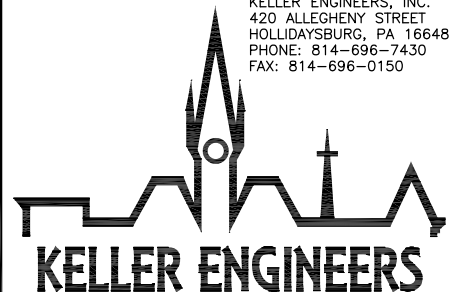

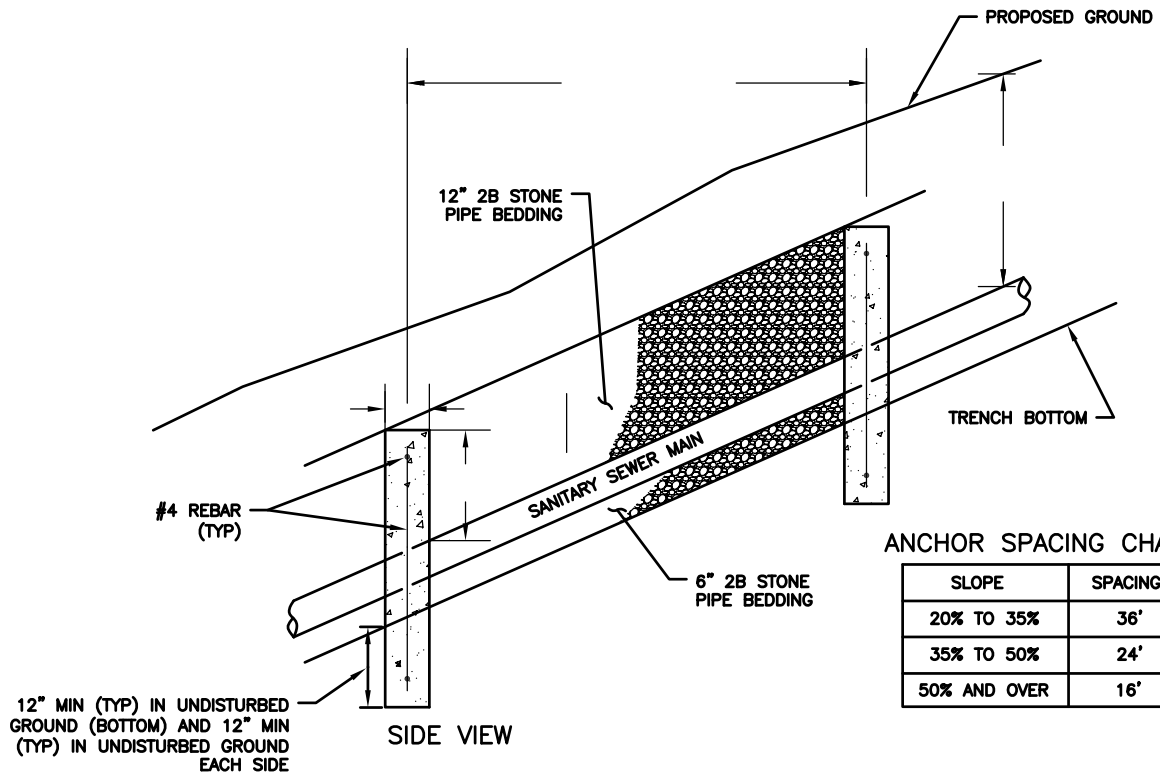

ANCHOR SPACING CHART

SLOPE	SPACING
20% TO 35%	36'
35% TO 50%	24'
50% AND OVER	16'

12" MIN (TYP) IN UNDISTURBED GROUND (BOTTOM) AND 12" MIN (TYP) IN UNDISTURBED GROUND EACH SIDE

SIDE VIEW

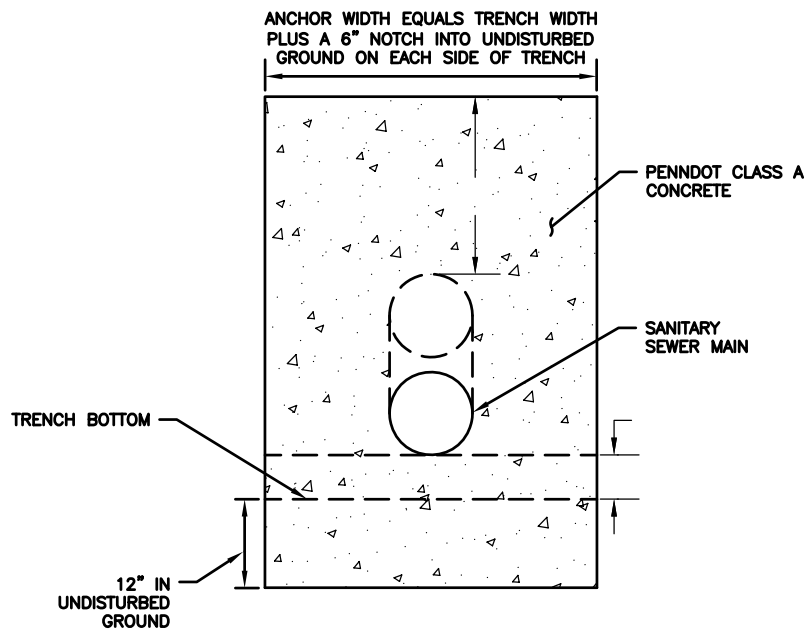

END VIEW

## STANDARD DETAILS CONCRETE PIPE ANCHOR

### BLAIR TOWNSHIP WATER AND SEWER AUTHORITY RULES, REGULATIONS AND POLICY

377 CEDARCREST DRIVE DUNCANSVILLE, PA 16635  
OFFICE: (814) 695-6300 FAX: (814) 696-5757  
TTY/TDD ONLY: 1-800-654-5984

BLAIR TOWNSHIP, BLAIR COUNTY  
PENNSYLVANIA

KELLER ENGINEERS, INC.  
420 ALLEGHENY STREET  
HOLLIDAYSBURG, PA 16648  
PHONE: 814-696-7430  
FAX: 814-696-0150

## KELLER ENGINEERS

In accordance with Federal law and U.S. Department of Agriculture policy, this institution is prohibited from discriminating on the basis of race, color, national origin, sex, age, or disability. (Not all prohibited bases apply to all programs). To file a complaint of discrimination, write USDA, Director, Office of Civil Rights, 1400 Independence Avenue, S.W., Washington D.C. 20250-9410, or call (800) 795-3272 (voice), or (202) 720-6382 (TDD)

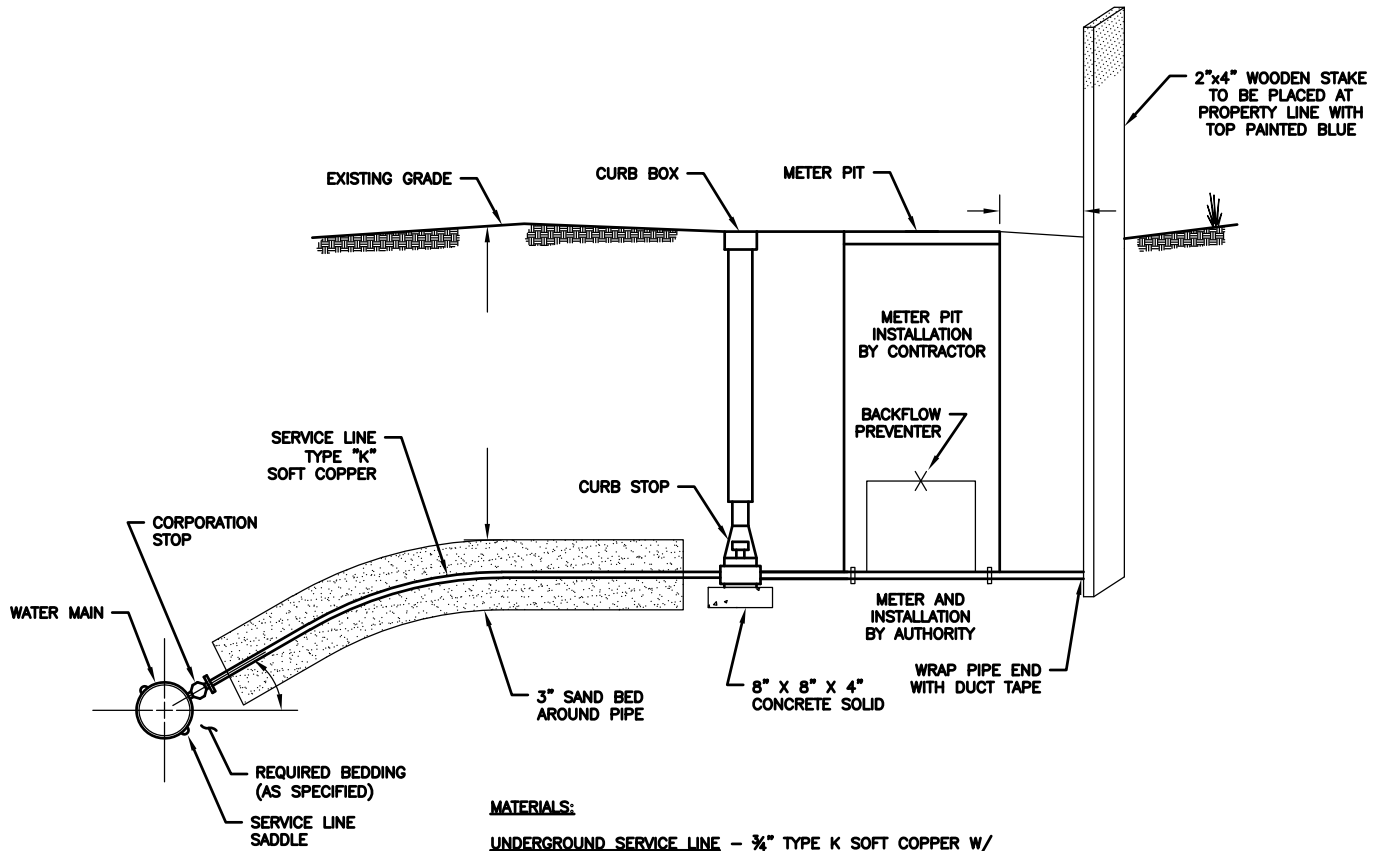

**MATERIALS:**

UNDERGROUND SERVICE LINE - 3/4" TYPE K SOFT COPPER W/  
COMPRESSION CONNECTION

BALL VALVE - 3/4" BRONZE BALL VALVE

BALL VALVE W/ DRAIN - 3/4" BALL AND WASTE FULL PORT BRONZE  
BALL VALVE, WATTS #B-6300 OR EQUAL

BACKFLOW PREVENTER - 3/4" BRONZE DUAL CHECK VALVE, WATTS #7  
(OR)

PRESSURE REGULATOR - BRONZE BODY PRESSURE REGULATOR W/  
STRAINER, WATTS #U5 OR EQUAL IF REQUIRED

## STANDARD DETAILS WATER CONNECTION

### BLAIR TOWNSHIP WATER AND SEWER AUTHORITY RULES, REGULATIONS AND POLICY

377 CEDARCREST DRIVE DUNCANVILLE, PA 16635  
OFFICE: (814) 695-6300 FAX: (814) 696-5757  
TTY/TDD ONLY: 1-800-654-5984

BLAIR TOWNSHIP, BLAIR COUNTY  
PENNSYLVANIA

KELLER ENGINEERS, INC.  
420 ALLEGHENY STREET  
HOLLIDAYSBURG, PA 16648  
PHONE: 814-696-7430  
FAX: 814-696-0150

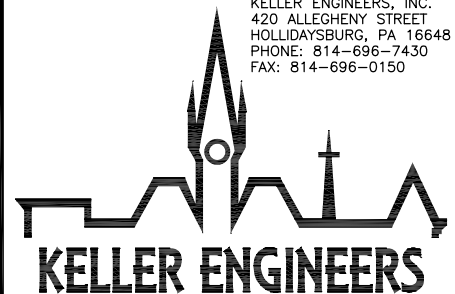

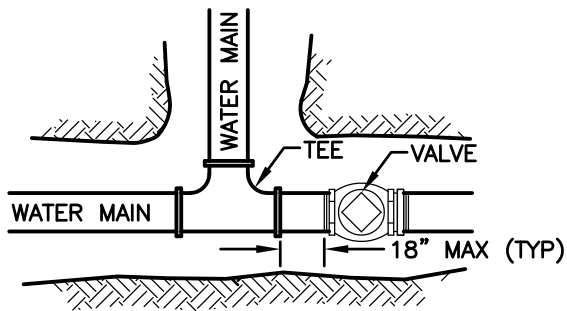

NOTE:  
TEES AND VALVES PLACED IN  
SUCCESSION SHALL BE SEPARATED  
BY NO MORE THAN 18"

## STANDARD DETAILS VALVE PLACEMENT

### BLAIR TOWNSHIP WATER AND SEWER AUTHORITY RULES, REGULATIONS AND POLICY

377 CEDARCREST DRIVE DUNCANSVILLE, PA 16635  
OFFICE: (814) 695-6300 FAX: (814) 696-5757  
TTY/TDD ONLY: 1-800-654-5984

BLAIR TOWNSHIP, BLAIR COUNTY  
PENNSYLVANIA

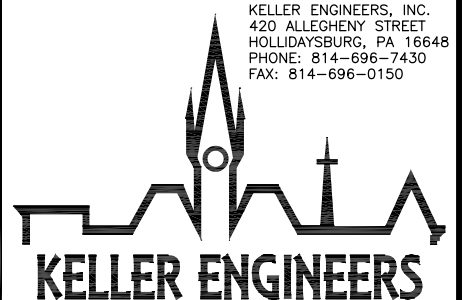

KELLER ENGINEERS, INC.  
420 ALLEGHENY STREET  
HOLLIDAYSBURG, PA 16648  
PHONE: 814-696-7430  
FAX: 814-696-0150

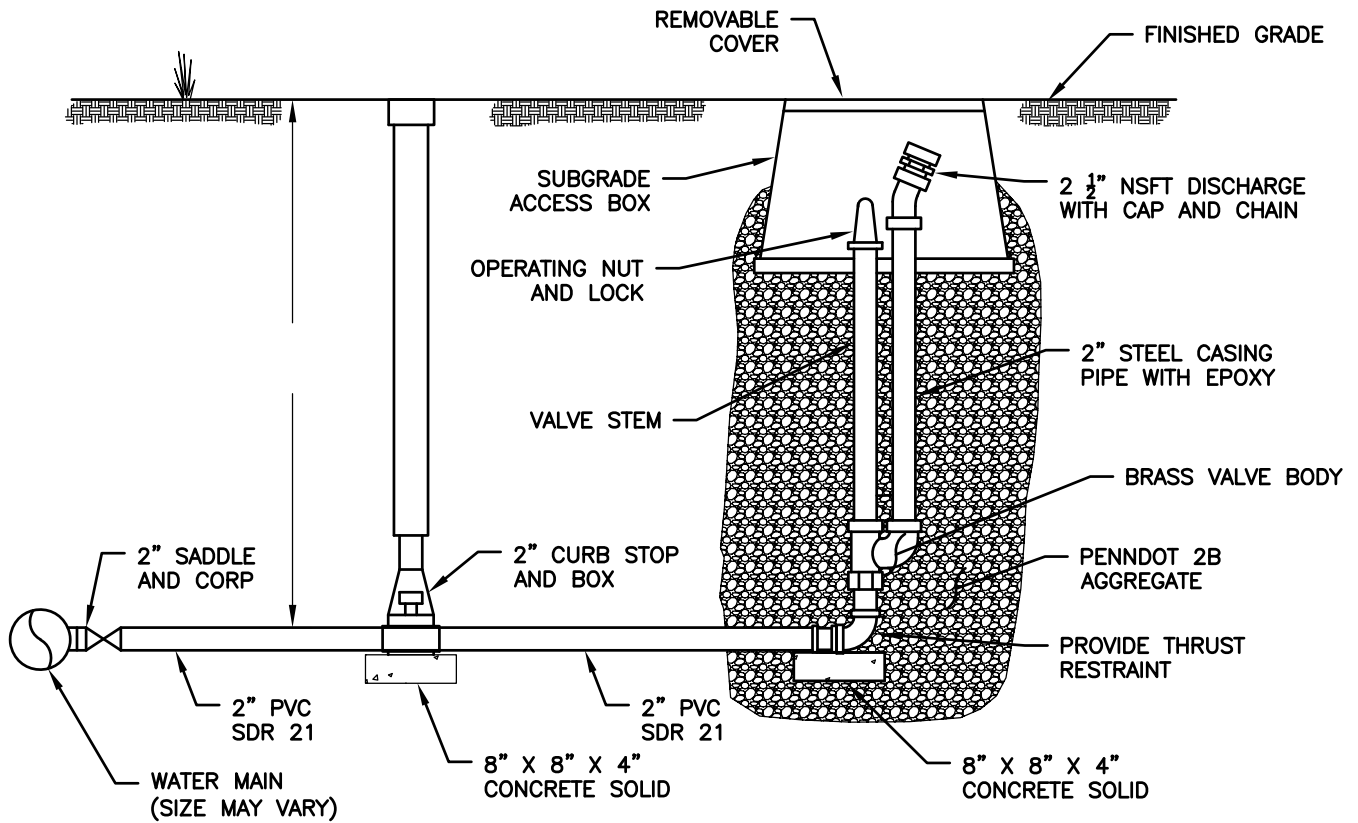

## STANDARD DETAILS BLOWOFF HYDRANT

### BLAIR TOWNSHIP WATER AND SEWER AUTHORITY RULES, REGULATIONS AND POLICY

377 CEDARCREST DRIVE DUNCANSVILLE, PA 16635  
 OFFICE: (814) 695-6300 FAX: (814) 696-5757  
 TTY/TDD ONLY: 1-800-654-5984

BLAIR TOWNSHIP, BLAIR COUNTY  
 PENNSYLVANIA

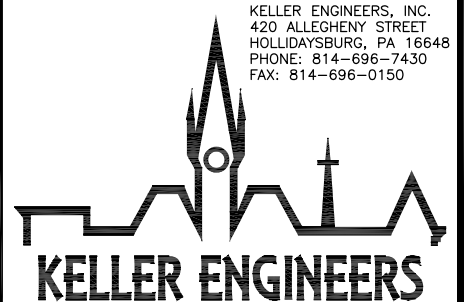

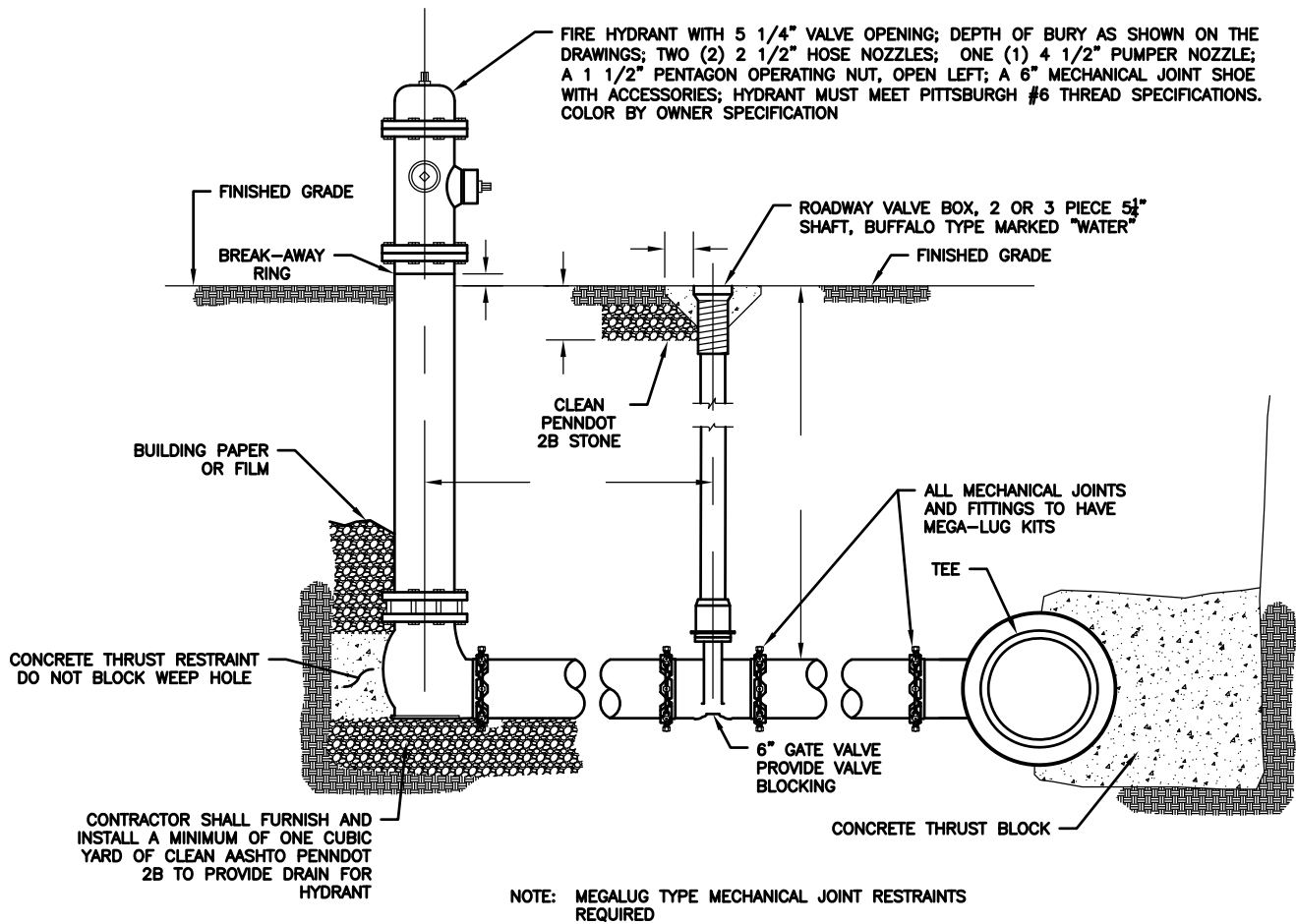

## STANDARD DETAILS FIRE HYDRANT ASSEMBLY

### BLAIR TOWNSHIP WATER AND SEWER AUTHORITY RULES, REGULATIONS AND POLICY

377 CEDARCREST DRIVE DUNCANSVILLE, PA 16635

OFFICE: (814) 695-6300 FAX: (814) 696-5757

TTY/TDD ONLY: 1-800-654-5984

BLAIR TOWNSHIP, BLAIR COUNTY  
PENNSYLVANIA

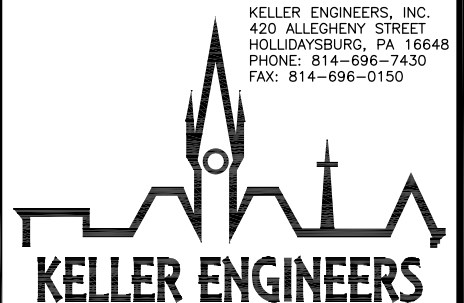

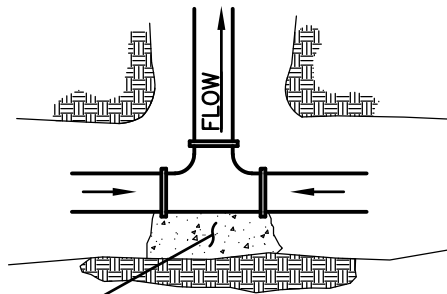
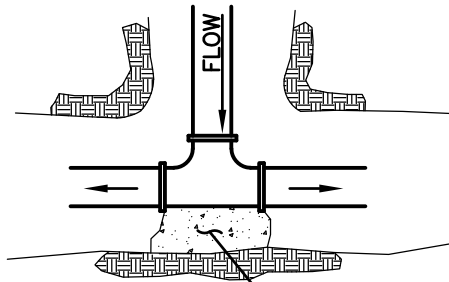
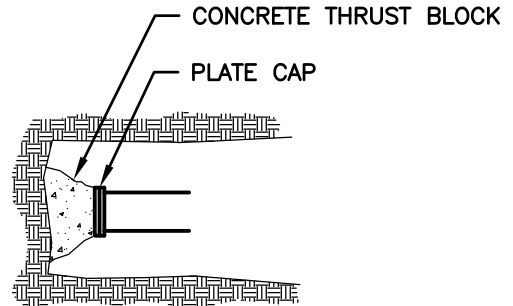
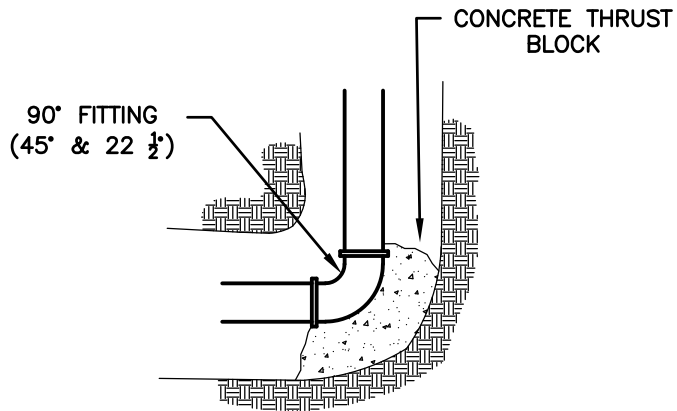

CONCRETE THRUST BLOCK

NOTE: CONCRETE TO BE PENNDOT CLASS A. PLACE PLASTIC BARRIER BETWEEN NUTS AND BOLTS AND CONCRETE

## STANDARD DETAILS THRUST BLOCK

### BLAIR TOWNSHIP WATER AND SEWER AUTHORITY RULES, REGULATIONS AND POLICY

377 CEDARCREST DRIVE DUNCANSVILLE, PA 16635  
OFFICE: (814) 695-6300 FAX: (814) 696-5757  
TTY/TDD ONLY: 1-800-654-5984

BLAIR TOWNSHIP, BLAIR COUNTY  
PENNSYLVANIA

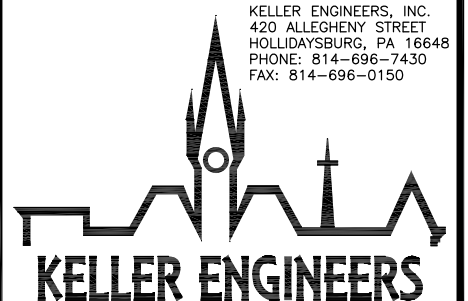

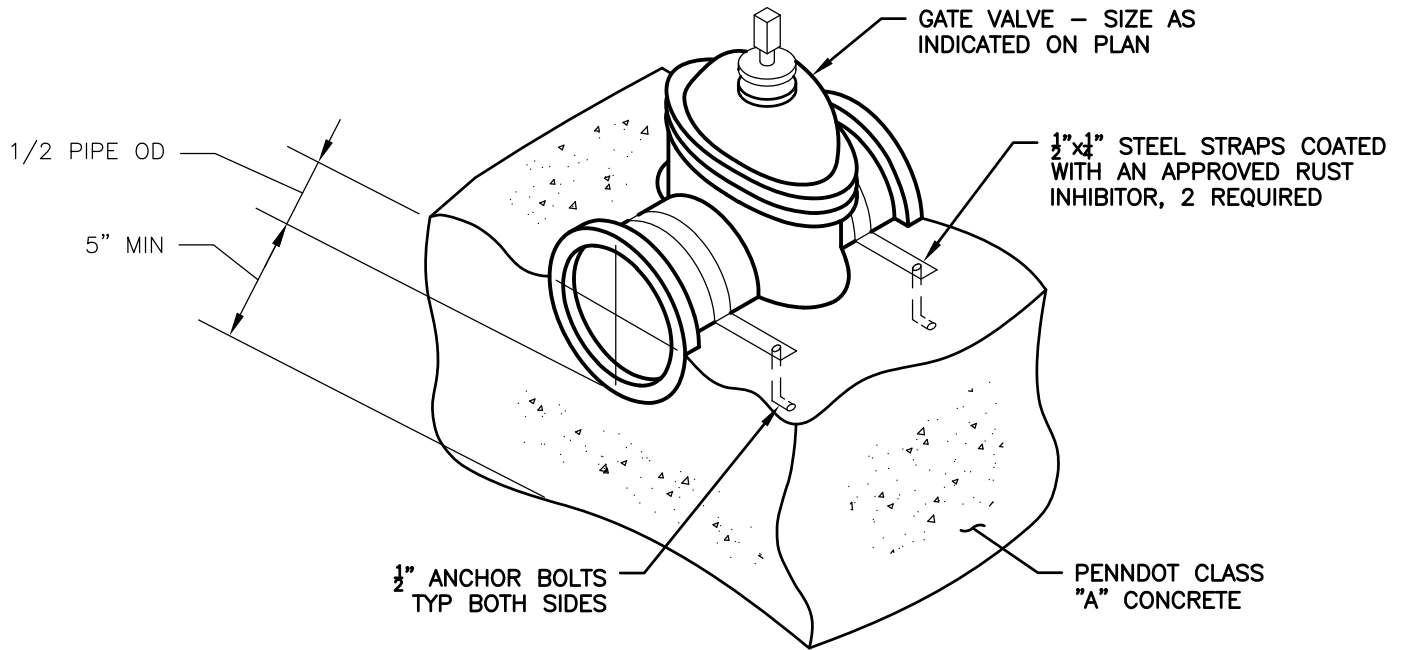

**NOTE:**  
CONCRETE NOT TO COVER BOLTS ON TOP OF STRAPS

## STANDARD DETAILS VALVE BLOCKING

### BLAIR TOWNSHIP WATER AND SEWER AUTHORITY RULES, REGULATIONS AND POLICY

377 CEDARCREST DRIVE DUNCANSVILLE, PA 16635

OFFICE: (814) 695-6300 FAX: (814) 696-5757

TTY/TDD ONLY: 1-800-654-5984

BLAIR TOWNSHIP, BLAIR COUNTY  
PENNSYLVANIA

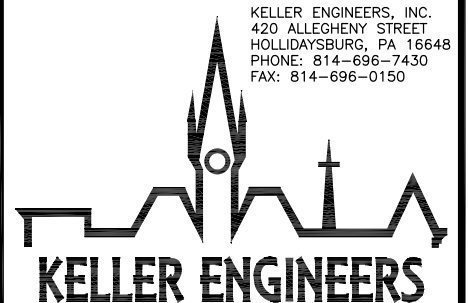

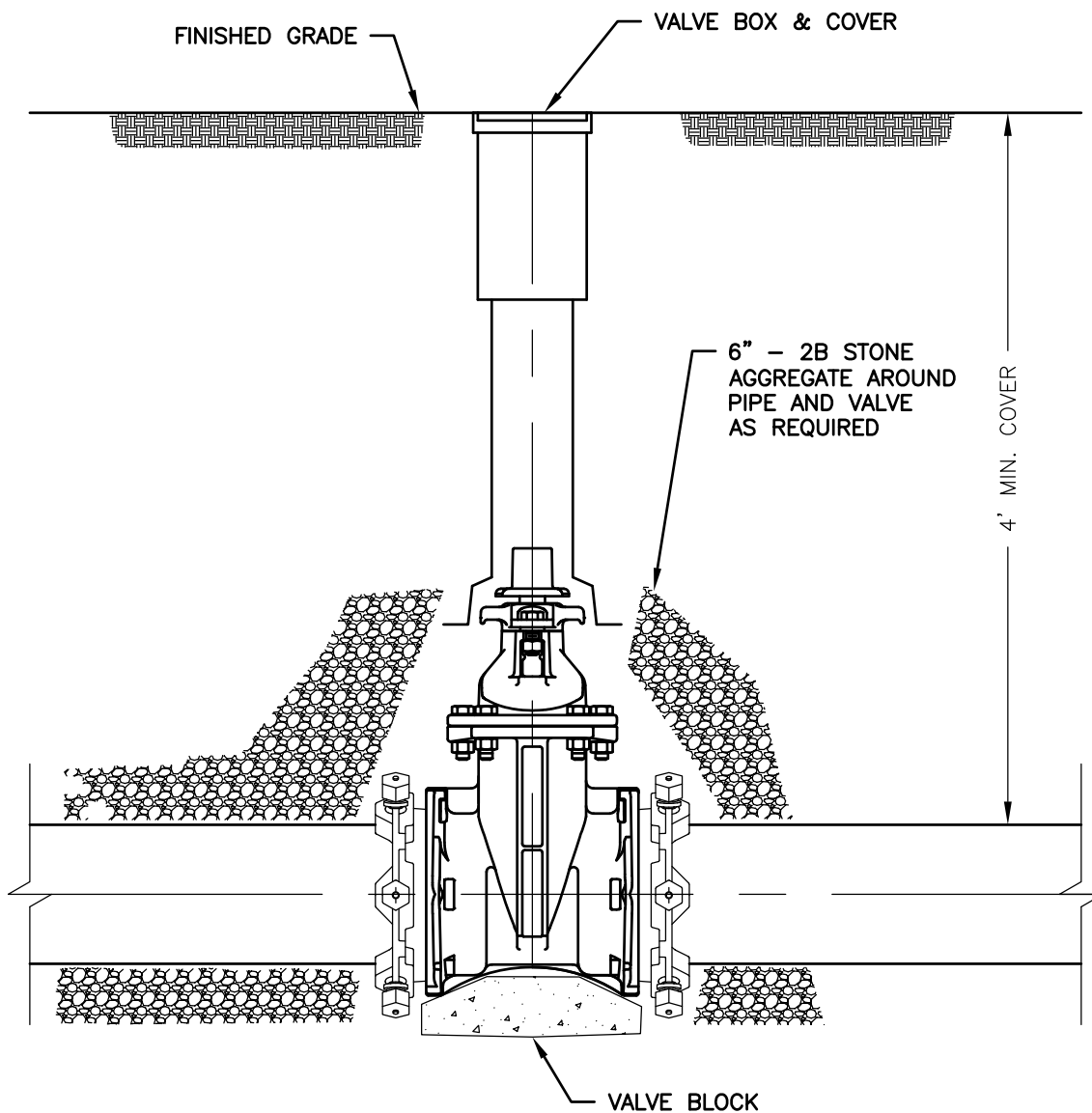

**STANDARD DETAILS**  
**CONCRETE PAD FOR VALVE BOX**

**BLAIR TOWNSHIP WATER AND SEWER AUTHORITY**  
**RULES, REGULATIONS AND POLICY**

377 CEDARCREST DRIVE DUNCANSVILLE, PA 16635  
 OFFICE: (814) 695-6300 FAX: (814) 696-5757  
 TTY/TDD ONLY: 1-800-654-5984

BLAIR TOWNSHIP, BLAIR COUNTY  
 PENNSYLVANIA

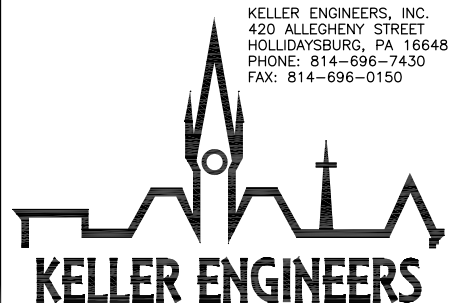

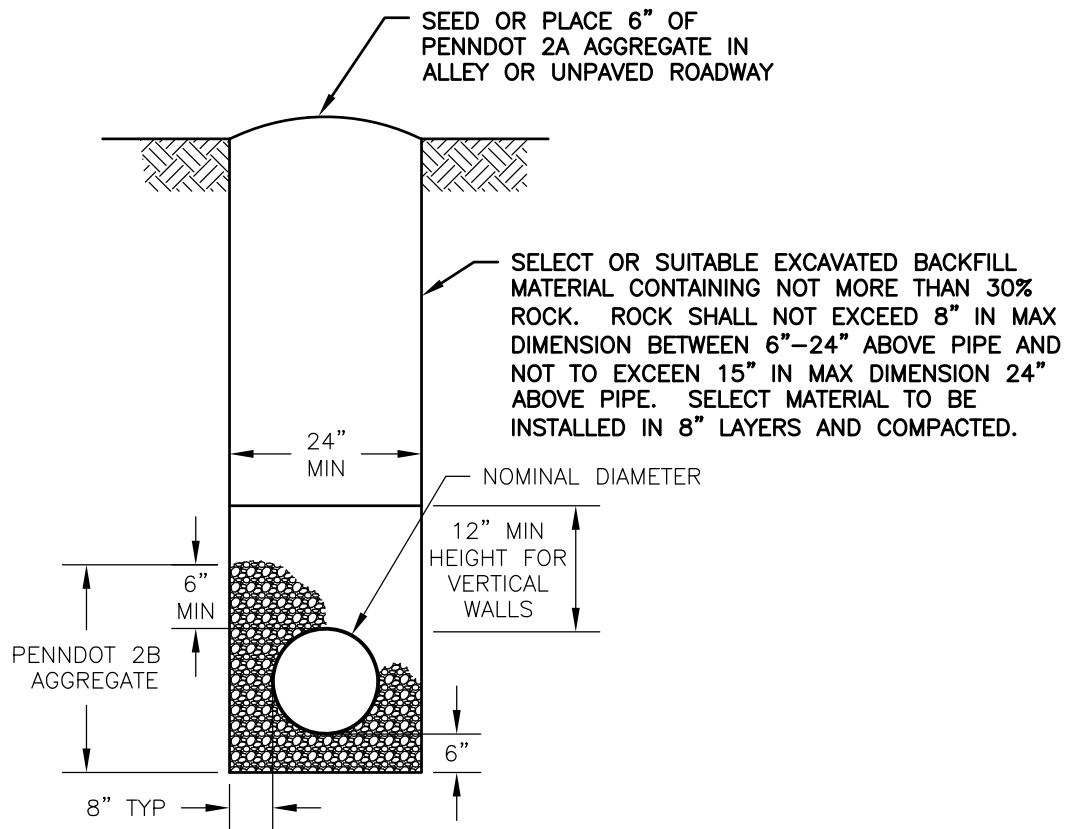

**STANDARD DETAILS  
PIPE INSTALLATION IN  
UNPAVED SURFACE**

**BLAIR TOWNSHIP WATER AND SEWER AUTHORITY  
RULES, REGULATIONS AND POLICY  
377 CEDARCREST DRIVE DUNCANSVILLE, PA 16635  
OFFICE: (814) 695-6300 FAX: (814) 696-5757  
TTY/TDD ONLY: 1-800-654-5984  
BLAIR TOWNSHIP, BLAIR COUNTY  
PENNSYLVANIA**

KELLER ENGINEERS, INC.  
420 ALLEGHENY STREET  
HOLLIDAYSBURG, PA 16648  
PHONE: 814-696-7430  
FAX: 814-696-0150

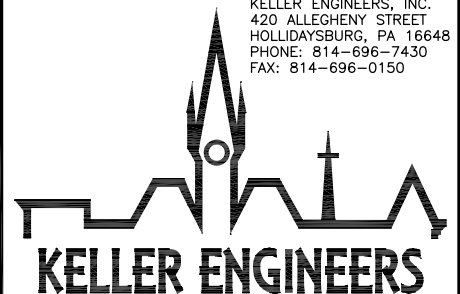

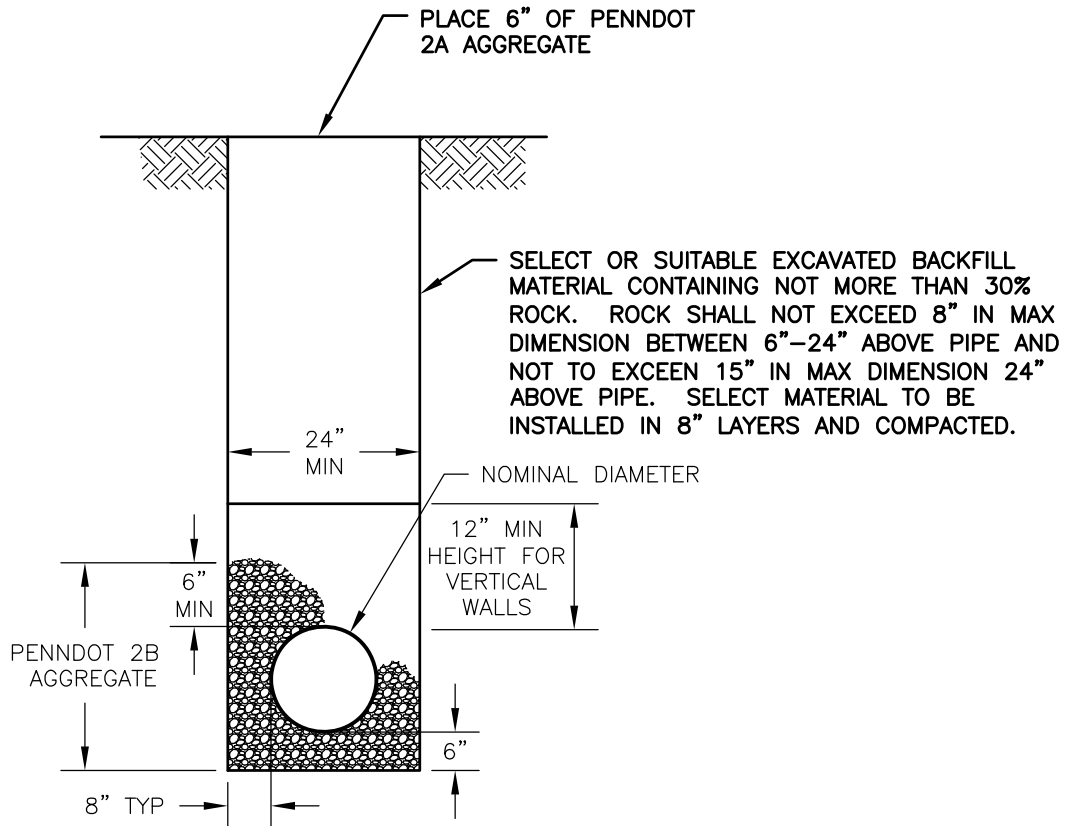

NOTE: TRENCH WALLS TO BE VERTICAL TO A DEPTH OF AT LEAST 12" ABOVE TOP OF PIPE

## STANDARD DETAILS PIPE INSTALLATION IN MUNICIPAL ROAD SHOULDER

BLAIR TOWNSHIP WATER AND SEWER AUTHORITY  
RULES, REGULATIONS AND POLICY  
377 CEDARCREST DRIVE DUNCANSVILLE, PA 16635  
OFFICE: (814) 695-6300 FAX: (814) 696-5757  
TTY/TDD ONLY: 1-800-654-5984  
BLAIR TOWNSHIP, BLAIR COUNTY  
PENNSYLVANIA

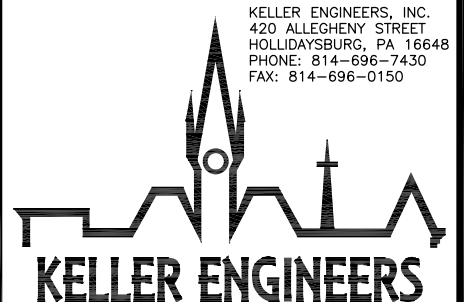

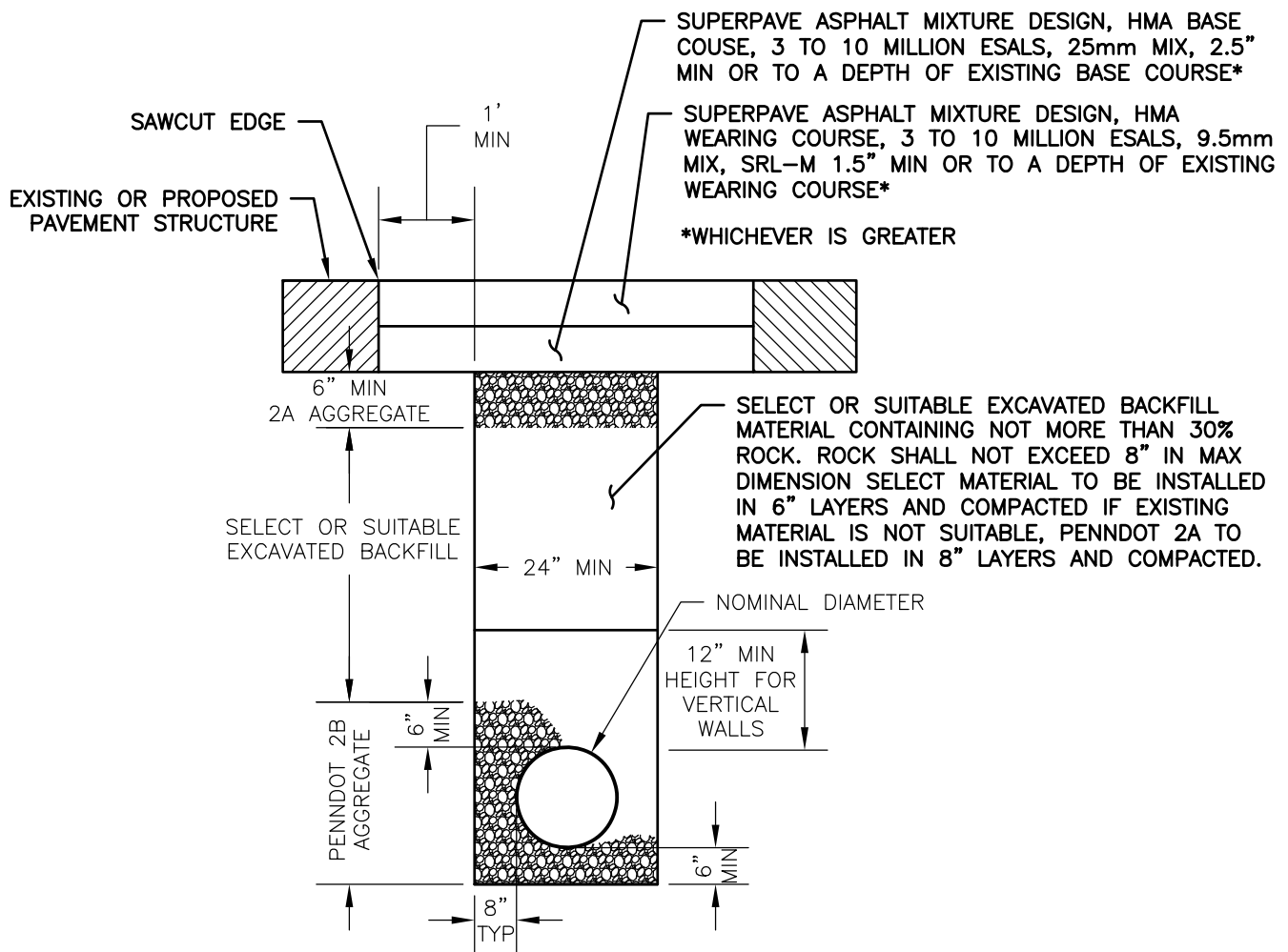

**STANDARD DETAILS  
PIPE INSTALLATION IN  
MUNICIPAL ROADWAY**

**BLAIR TOWNSHIP WATER AND SEWER AUTHORITY  
RULES, REGULATIONS AND POLICY  
377 CEDARCREST DRIVE DUNCANSVILLE, PA 16635  
OFFICE: (814) 695-6300 FAX: (814) 696-5757  
TTY/TDD ONLY: 1-800-654-5984  
BLAIR TOWNSHIP, BLAIR COUNTY  
PENNSYLVANIA**

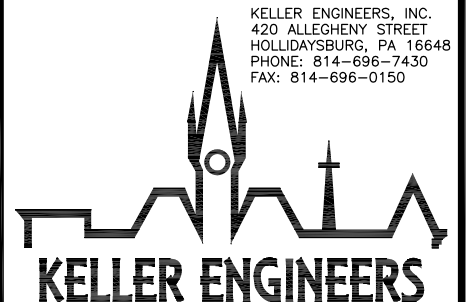

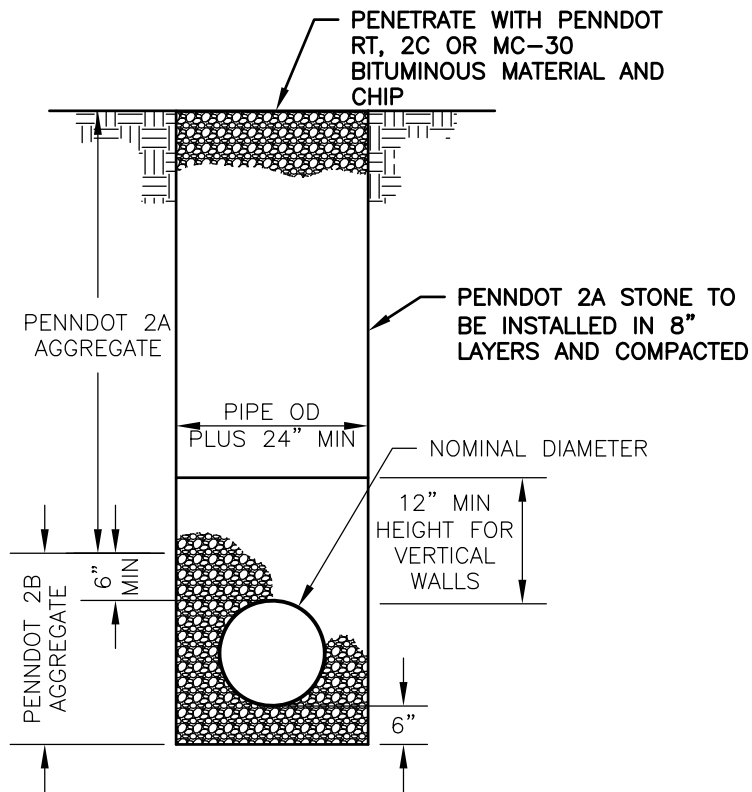

**NOTE:**

1. PIPE OD PLUS 30" MIN ON PIPE LARGER THAN 48"

**STANDARD DETAILS  
PIPE INSTALLATION IN  
STATE ROADWAY SHOULDER**

**BLAIR TOWNSHIP WATER AND SEWER AUTHORITY  
RULES, REGULATIONS AND POLICY  
377 CEDARCREST DRIVE DUNCANSVILLE, PA 16635  
OFFICE: (814) 695-6300 FAX: (814) 696-5757  
TTY/TDD ONLY: 1-800-654-5984  
BLAIR TOWNSHIP, BLAIR COUNTY  
PENNSYLVANIA**

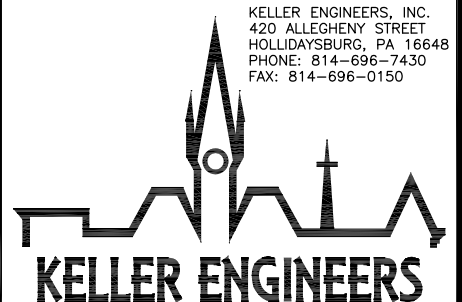

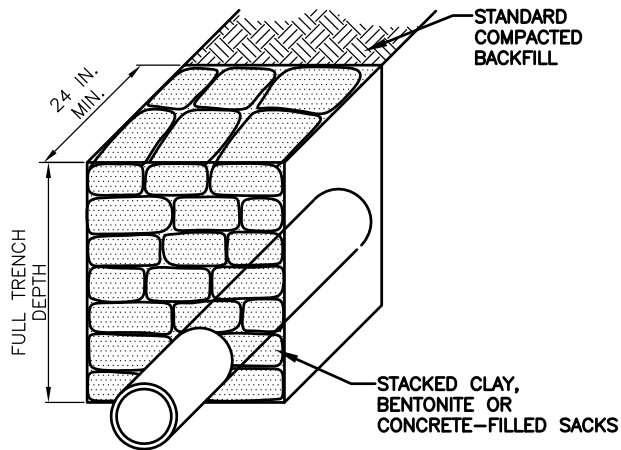

**SECTION VIEW**

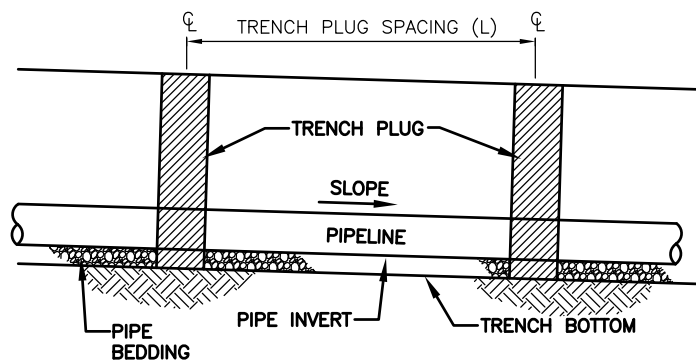

**PROFILE VIEW**

PA DEP EROSION CONTROL MANUAL TABLE 13.1  
MAXIMUM SPACING AND MATERIALS FOR TRENCH PLUGS

TRENCH SLOPE (%)	SPACING L (FT)	PLUG MATERIAL
< 5	1000	* CLAY, BENTONITE, OR CONCRETE FILLED SACKS
5 - 15	500	* CLAY, BENTONITE, OR CONCRETE FILLED SACKS
15 - 25	300	* CLAY, BENTONITE, OR CONCRETE FILLED SACKS
25 - 35	200	* CLAY, BENTONITE, OR CONCRETE FILLED SACKS
35 - 100	100	* CLAY, BENTONITE, OR CONCRETE FILLED SACKS
> 100	50	CEMENT BAGS (WETTED) OR MORTARED STONE

\* TOPSOIL MAY NOT BE USED TO FILL SACKS

**NOTES:**

IMPERVIOUS TRENCH PLUGS ARE REQUIRED FOR ALL STREAM, RIVER, WETLAND, OR OTHER WATER BODY CROSSINGS.

## STANDARD DETAILS TRENCH PLUG INSTALLATION

### BLAIR TOWNSHIP WATER AND SEWER AUTHORITY RULES, REGULATIONS AND POLICY

377 CEDARCREST DRIVE DUNCANVILLE, PA 16635  
OFFICE: (814) 695-6300 FAX: (814) 696-5757  
TTY/TDD ONLY: 1-800-654-5984

BLAIR TOWNSHIP, BLAIR COUNTY  
PENNSYLVANIA

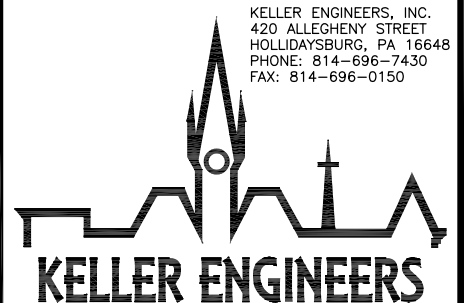

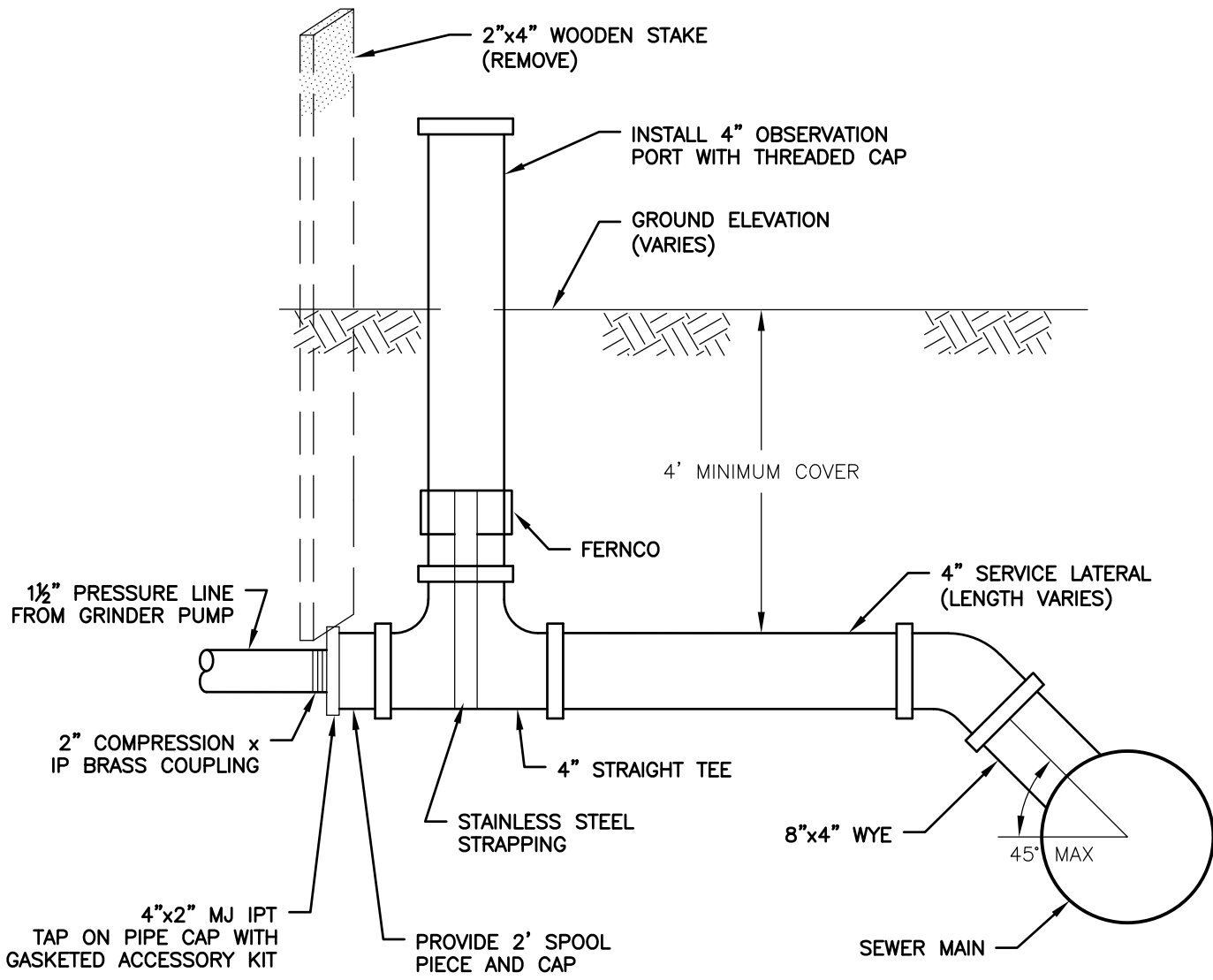

**STANDARD DETAILS  
PRESSURE CONNECTION TO  
GRAVITY LINE**

**BLAIR TOWNSHIP WATER AND SEWER AUTHORITY  
RULES, REGULATIONS AND POLICY**  
377 CEDARCREST DRIVE DUNCANVILLE, PA 16635  
OFFICE: (814) 695-6300 FAX: (814) 696-5757  
TTY/TDD ONLY: 1-800-654-5984  
BLAIR TOWNSHIP, BLAIR COUNTY  
PENNSYLVANIA

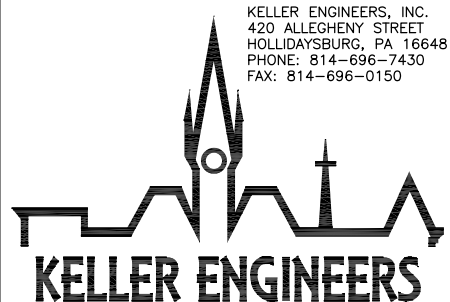

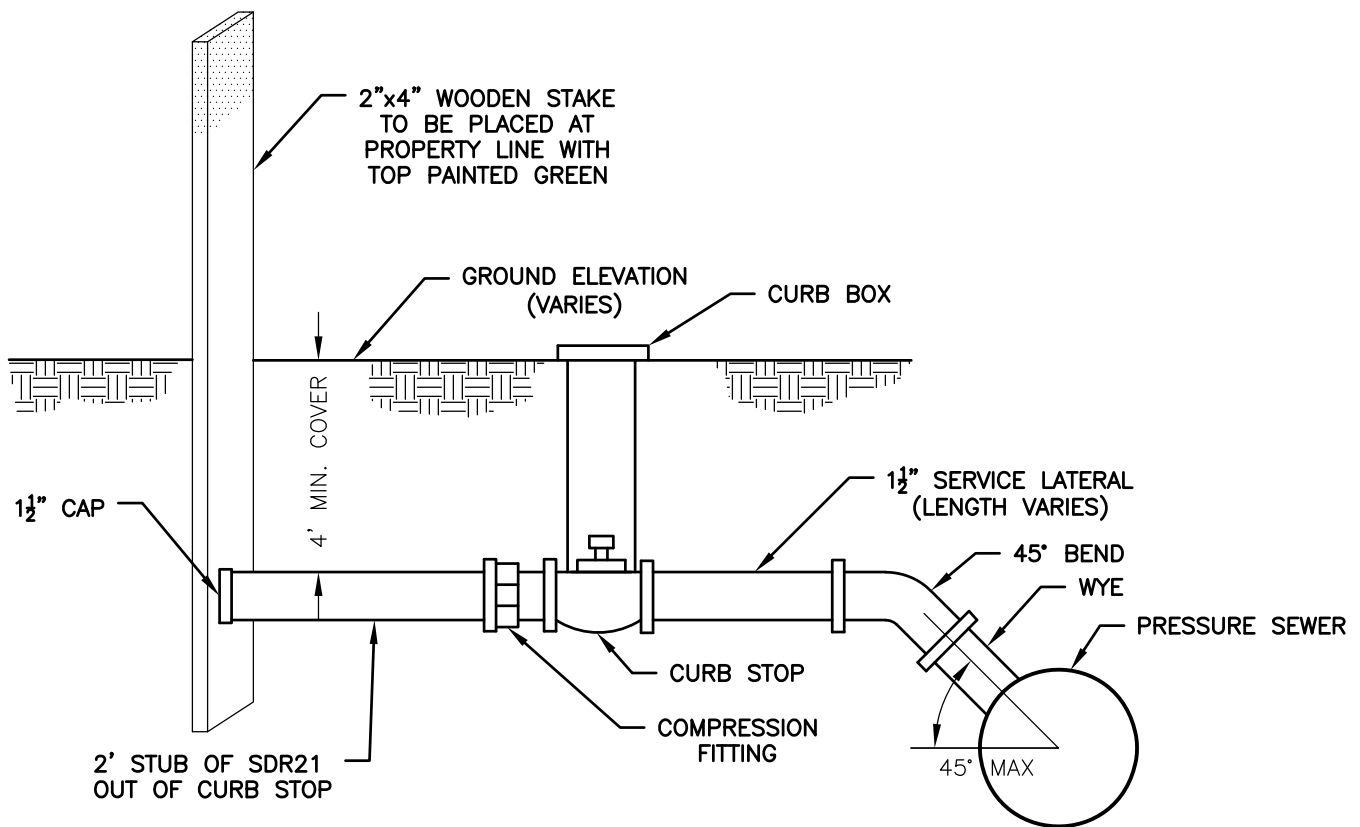

**NOTE:**  
CONTRACTOR RESPONSIBLE FOR COORDINATING  
LATERAL LOCATION WITH PROPERTY OWNER

## STANDARD DETAILS PRESSURE CONNECTION TO PRESSURE LINE

BLAIR TOWNSHIP WATER AND SEWER AUTHORITY  
RULES, REGULATIONS AND POLICY  
377 CEDARCREST DRIVE DUNCANSVILLE, PA 16635  
OFFICE: (814) 695-6300 FAX: (814) 696-5757  
TTY/TDD ONLY: 1-800-654-5984  
BLAIR TOWNSHIP, BLAIR COUNTY  
PENNSYLVANIA

